

13 & 15 Kelsey Road SALISBURY NORTH SA

6 🚗 2 🚗 2 🚗

For an in-depth look at this home, please click on the 3D tour for a virtual walk-through or copy and paste this link into your browser

Virtual Tour Link: <https://shorturl.at/L9mBm>

To submit an offer, please copy and paste this link into your browser:

<https://www.edgerealty.com.au/buying/make-an-offer/>

Mike Lao, Brendon Ly and Edge Realty RLA256385 are proud to present to the market the chance to purchase two semi-detached homes situated on a generous total 1,403sqm approx corner block, perfect for those who need more space or are looking for future development opportunities (STCA). While number 15 is vacant and

[For full version visit the website](https://www.edgerealty.com.au)

Type : House
Price : Best Offers by 9am Tues 19/11/24 (USP) Guide \$1.3m
Building Size : 150 sqm
Land Size : 1403 sqm
View : <https://www.edgerealty.com.au/sale/sa/north-north-east-suburbs/salisbury-north/residential/house/8155011>



Mike Lao



Brendon Ly

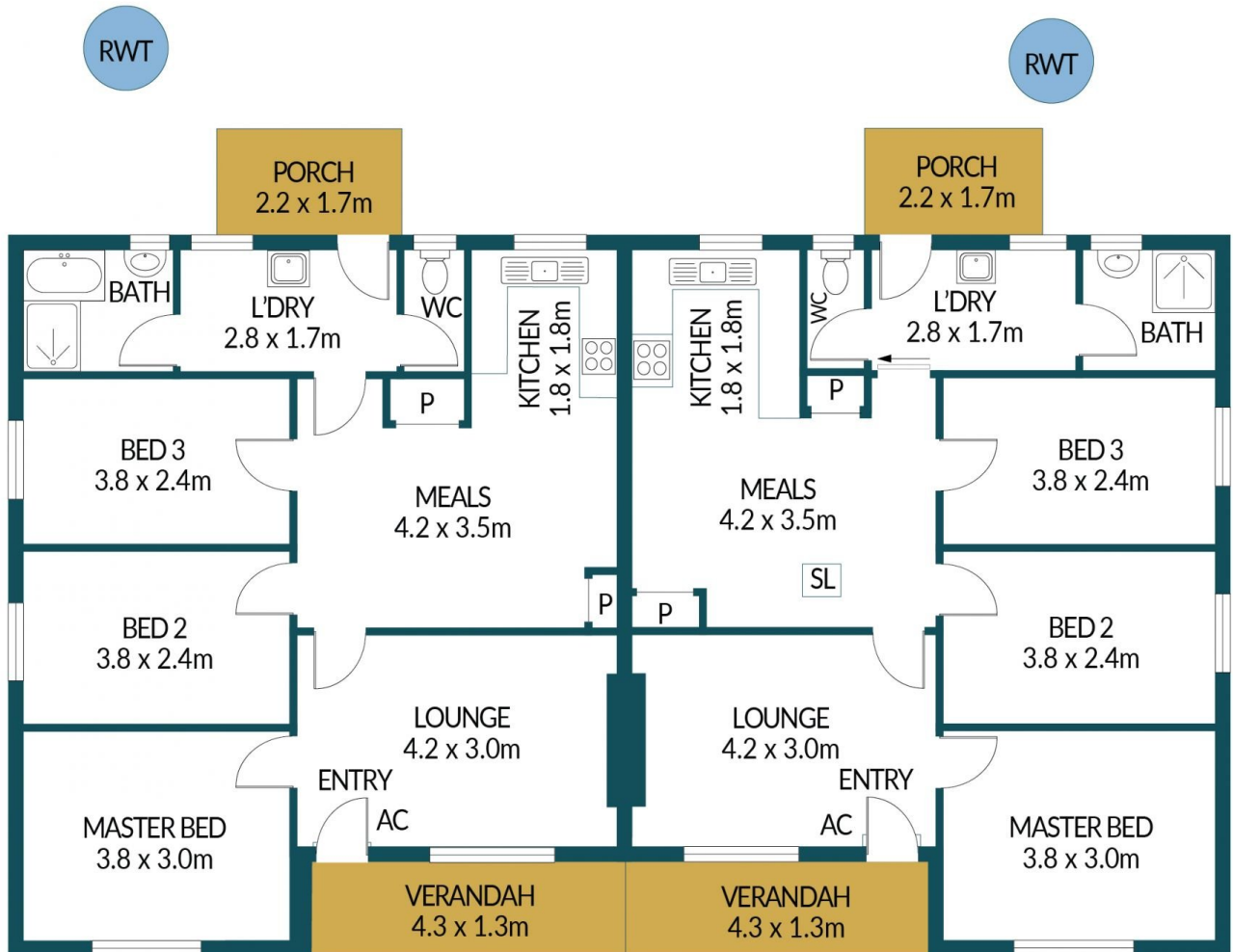

13 & 15 KELSEY ROAD, SALISBURY NORTH

Disclaimer

Plans shown are for marketing purposes only. All dimensions and placements are approximate and not to scale. They are subject to errors and inaccuracies and no liability will be accepted. Interested parties should make their own enquiries. Inclusions and exclusions must be confirmed in the Residential Contract.

APPROXIMATE DIMENSIONS

LIVING:	150.8m ²
VERANDAH:	11.2m ²
PORCH:	7.4m ²
TOTAL:	169.4m ²